

Technics®

Audio Mixer

SH-DJ1200

Operating Instructions

Note:

The "EB" indication shown on the packing case indicates United Kingdom.

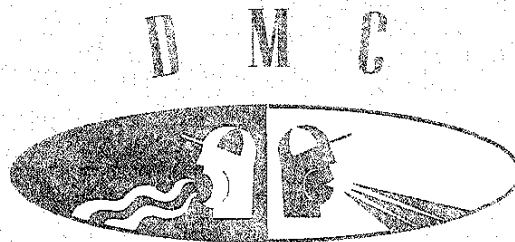
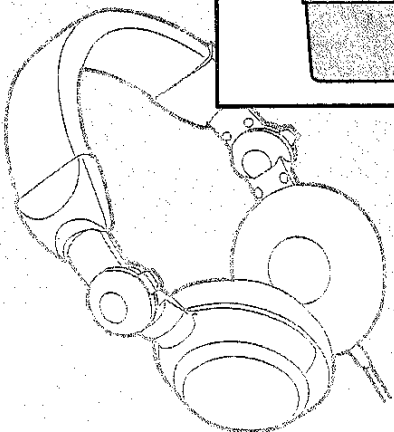
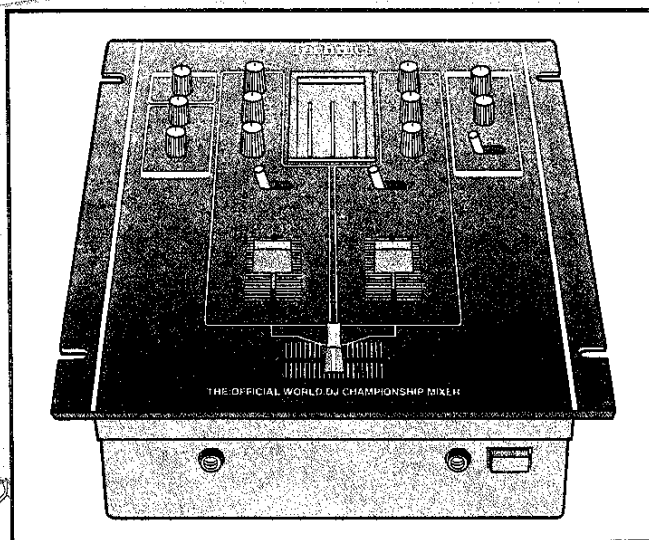
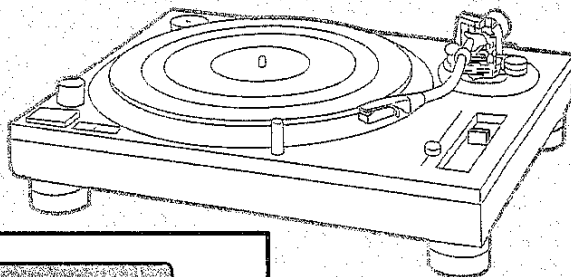
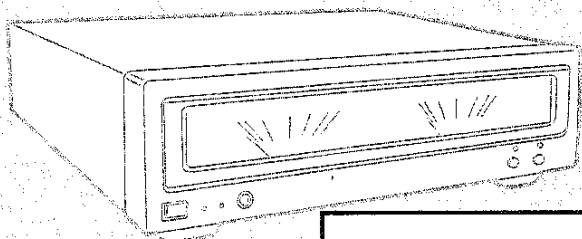

Dear Customer

Thank you for purchasing this audio mixer.
For optimum performance and safety, please read these operating instructions carefully.

Before connecting, operating or adjusting this product, please read these instructions completely. Please save this manual.

Suggestions for Safety

Placement

Avoid placing the unit in areas of:

- direct sunlight
- high temperature
- high humidity
- excessive vibration
- uneven surfaces (Place the unit on a flat level surface.)

Such conditions might damage the cabinet and/or other component parts and thereby shorten the unit's service life.

Ventilation

Place the unit in a well ventilated position at least 10 cms away from wall surfaces etc.

Stacking

Never place heavy items on top of the unit or the mains lead.

Voltage

- It is very dangerous to use an AC power source of high voltage such as for an air conditioner.
A fire might be caused by such a connection.
- A DC power source can not be used.
Be sure to check the power source carefully, especially on a ship or other place where DC is used.

Mains lead protection

- Avoid cuts, scratches or poor connection of the AC mains lead, as this may result in fire or electric shock hazard.
Excessive bending, pulling or slicing of the lead should also be avoided.
- Do not pull on the lead when you are disconnecting the power, as this could cause an electric shock. Grasp the plug firmly when you disconnect the mains.
- Never touch the plug with wet hands or a serious electric shock could result.

Contents

Suggestions for Safety	2
Caution for AC Mains Lead	3
Features	4
Supplied Accessories	4
Connections	5
Names of the Parts	8
Block Diagram	10
Technical Specifications	11
Troubleshooting Guide	Back cover
Maintenance	Back cover

Foreign materials

- Ensure that no foreign objects, such as needles, coins, screwdrivers etc, accidentally fall into the unit.
Otherwise, a serious electric shock or malfunction could occur.
- Be extremely careful about spilling water or liquid on/into the unit, as a fire or electric shock could occur.
(Disconnect the power plug and contact your dealer immediately if this occurs.)
- Avoid spraying insecticides onto the unit as they contain flammable gases which can be ignited.
- Insecticides, alcohol, paint thinner and similar chemicals should never be used to clean the unit as they can cause flaking or cloudiness to the cabinet finish.

Maintenance

Clean the cabinet, panel and controls with a soft cloth lightly moistened with mild detergent solution.

Do not use any type of abrasive pad, scouring powder or solvent such as alcohol or benzene.

Service

- Never attempt to repair, disassemble or reconstruct the unit if there seems to be a problem.
A serious electric shock could result if you ignore this precautionary measure.
- If a problem occurs during operation (the sound is interrupted, indicators fail to illuminate, smoke is detected, etc.) contact your dealer or Authorized Service Center immediately.
- Disconnect the mains if the unit will not be used for a long time.
Otherwise the operation life could be shortened.

Caution for AC Mains Lead

(For United Kingdom)

("EB" area code model only)

For your safety, please read the following text carefully.

This appliance is supplied with a moulded three pin mains plug for your safety and convenience.

A 5-ampere fuse is fitted in this plug.

Should the fuse need to be replaced please ensure that the replacement fuse has a rating of 5-ampere and that it is approved by ASTA or BSI to BS1362.

Check for the ASTA mark  or the BSI mark  on the body of the fuse.

If the plug contains a removable fuse cover you must ensure that it is refitted when the fuse is replaced.

If you lose the fuse cover the plug must not be used until a replacement cover is obtained.

A replacement fuse cover can be purchased from your local dealer.

CAUTION!

IF THE FITTED MOULDED PLUG IS UNSUITABLE FOR THE SOCKET OUTLET IN YOUR HOME THEN THE FUSE SHOULD BE REMOVED AND THE PLUG CUT OFF AND DISPOSED OF SAFELY.

THERE IS A DANGER OF SEVERE ELECTRICAL SHOCK IF THE CUT OFF PLUG IS INSERTED INTO ANY 13-AMPERE SOCKET.

If a new plug is to be fitted please observe the wiring code as shown below.

If in any doubt please consult a qualified electrician.

IMPORTANT

The wires in this mains lead are coloured in accordance with the following code:

Blue: Neutral, Brown: Live.

As these colours may not correspond with the coloured markings identifying the terminals in your plug, proceed as follows:

The wire which is coloured Blue must be connected to the terminal which is marked with the letter N or coloured Black or Blue.

The wire which is coloured Brown must be connected to the terminal which is marked with the letter L or coloured Brown or Red.

WARNING: DO NOT CONNECT EITHER WIRE TO THE EARTH TERMINAL WHICH IS MARKED WITH THE LETTER E, BY THE EARTH SYMBOL \perp OR COLOURED GREEN OR GREEN/YELLOW.

THIS PLUG IS NOT WATERPROOF—KEEP DRY.

Before use

Remove the connector cover.

How to replace the fuse

The location of the fuse differ according to the type of AC mains plug (figures A and B). Confirm the AC mains plug fitted and follow the instructions below.

Illustrations may differ from actual AC mains plug.

1. Open the fuse cover with a screwdriver.

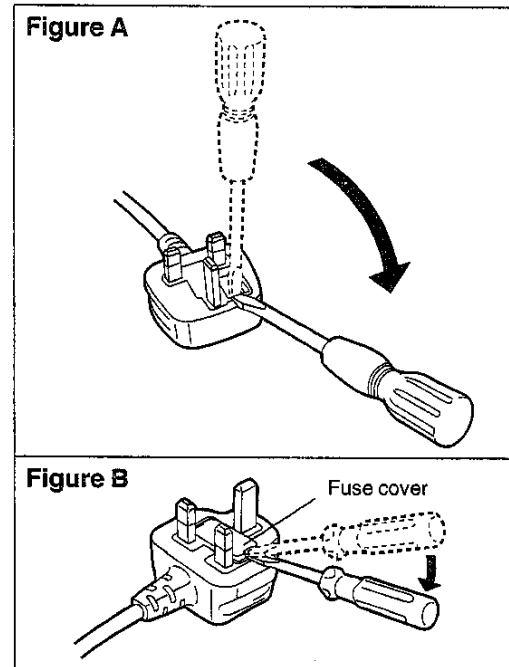

2. Replace the fuse and close or attach the fuse cover.

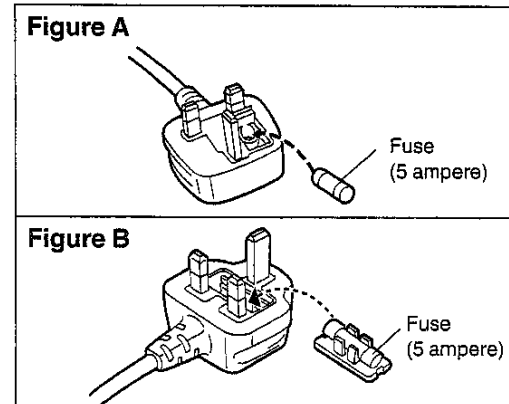

Features

This model is the official audio mixer for the DMC-sponsored World DJ Championship to be held each year in 1997 and beyond. The event will bring together professional disc jockeys from all over the world to compete for top honors. It is a top-of-the-line audio mixer with the kind of outstanding design, functions and sound quality that suits the requirements of disc jockeys accustomed to giving scratch-mixing performances in a variety of different ways.

Operating ease

- This audio mixer is designed with the same height as that of the SL-1200MK2 for operating ease.
- By providing adequate space in the panel layout around the channel faders and cross fader and by eliminating the protruding parts, full rein can be given to individual technique which exactly reflects the mood of the moment even when it comes to high-powered scratch-mixing.

Functions

- The model comes with both high and low equalizers so that all manner of sound sources can be accommodated to generate a highly creative style of sound. A wide margin of creativity in producing sound is provided since the attenuation is set to a high -24 dB (12 dB/oct).

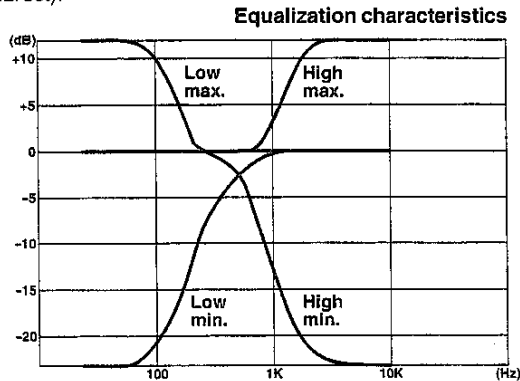

- The model is equipped with TRIM controls (± 10 dB) which compensate for differences in the source level.
- By adding a pre-fader monitor, the channels selected by the CUE controls can be monitored regardless of the positions of the faders. It is also possible to mix and monitor the line-out sources.
- The model comes with line-out connectors for monitoring so that sound can be monitored not only with headphones but through the speakers inside the booth.
- The line-out source L and R levels as well as the monitor source levels can be checked out on the 12-point, 3-column level meter.
- An AUX IN connector is provided to enable a sampler, keyboard, etc. to become part of the disc jockey scene.

Construction and materials

- New 45 mm stroke faders with an excellent durability and smooth operating touch have been developed for this model. The service life of the channel faders and cross fader has been improved by a quantum leap (an approximately 10-fold increase over existing models; nominal service life: 100,000 operations).
- A spare channel fader and a spare cross fader have been provided on the back panel just in case, and the faders themselves are designed to enable easy replacement.
- Lever switches are employed for the input selector controls (LINE, PHONO) and, by providing adequate space around them, they can also be used for operations involving the transformer scratch function.
- The panels are made of aluminum, and the surfaces have a glossy finish with a tough black coating which makes it hard for the markings to be worn away.

What is DMC?

DMC is the world's largest disc jockey organization whose members include the world's top disc jockeys, musicians and producers. Its objective is to contribute to improvements in the creation of music by its members. With main offices in England (London) and the United States (New York), it has branches in 32 countries throughout the world. Through its many activities which include the publication of "MIX MAG", the world's best-selling dance music trade magazine, DMC has sponsored the World DJ Championship for the last ten years with the support of Technics. At this venue which is held in London's Albert Hall or Wembley Stadium, the disc jockeys from 32 nations around the globe who have won top honors in the championships held in their respective countries put on their most impressive shows and compete to determine who will be crowned as world champion.

Supplied Accessories



Please check and identify the supplied accessories.

AC mains lead 1 pc.

For United Kingdom
(VJA0733)

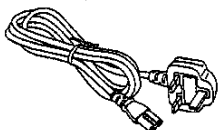

For others
(RJA0035-K)

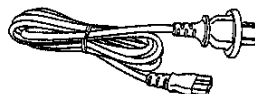

Sticker 1 pc.
(RFE0032)

Technics

Use numbers indicated in parentheses when asking for replacement parts.

Connections

Rear panel connections

This model is connected with the other equipment using stereo connection cables (not included). Before proceeding with the connections, make absolutely sure that the power is turned off to the units concerned.

Connect the power cord after all the other connections have been completed.

For your reference:

The grounding wire need not be connected if the turntable does not have a GND terminal.

Insertion of Connector A

Even when the connector is perfectly inserted, depending on the type of inlet used, the front part of the connector may jut out as shown in the drawing. However there is no problem using the unit.

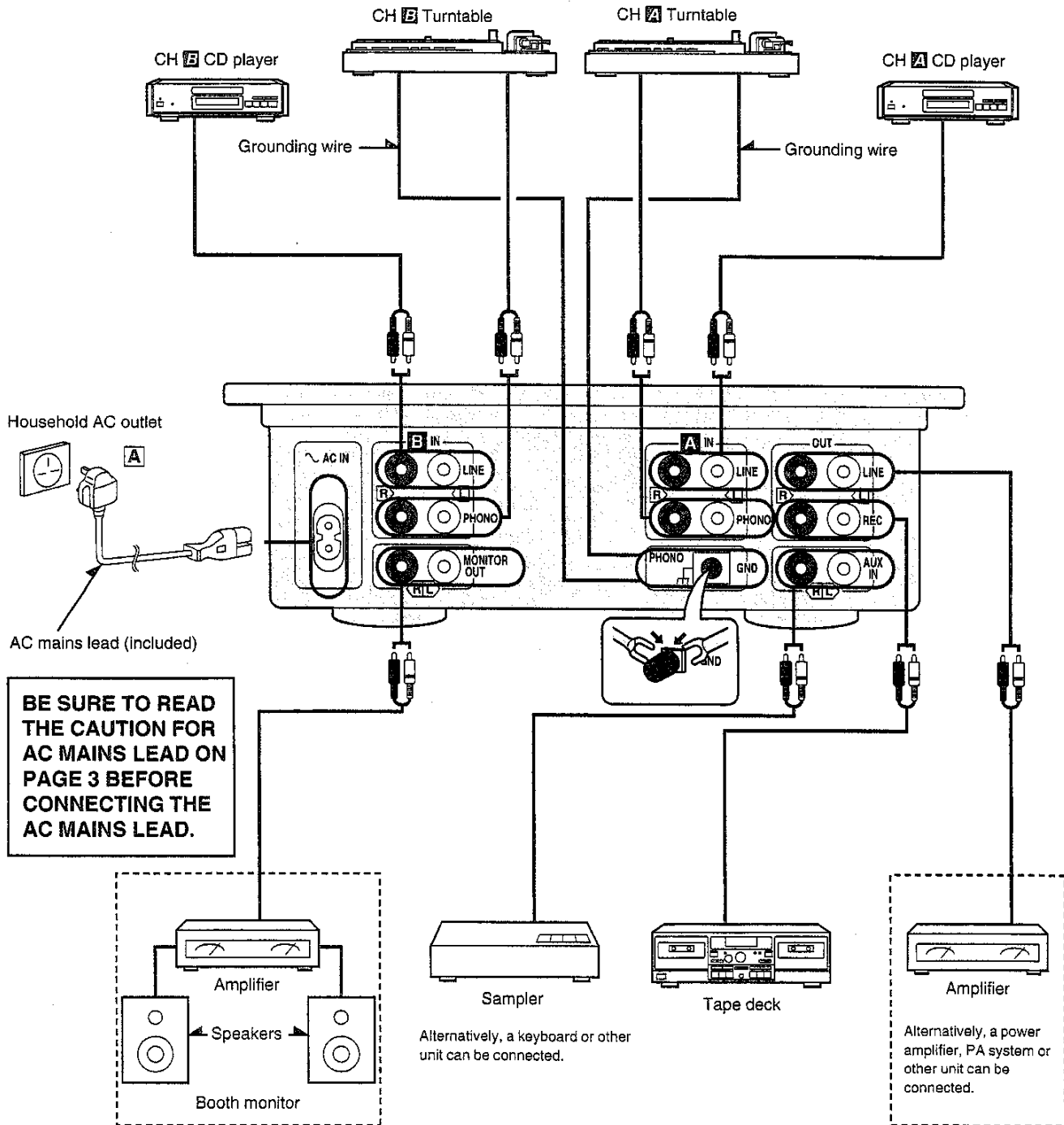
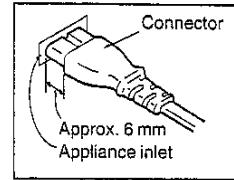

Connections

Front panel connections

To listen with the headphones:

- Before connecting the headphones, be absolutely sure to turn down the volume setting using the monitor volume level control, etc.
- Avoid listening for prolonged periods of time to prevent hearing damage.

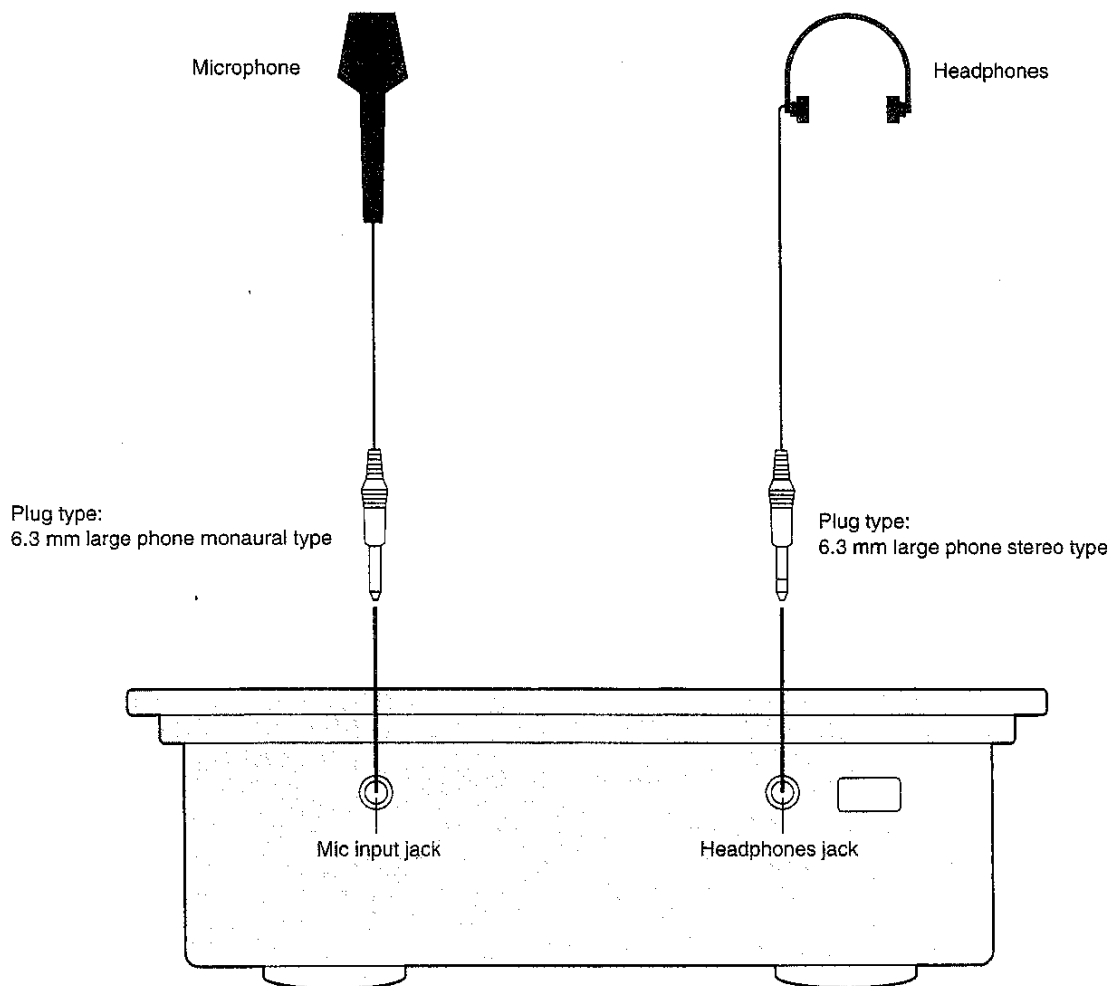

Connecting two audio mixers side by side

Connect the LINE OUT connector of the sub mixer to the AUX IN connector on the master mixer.

How to align the volume levels of the master and sub mixers:

Adjust the AUX/EFFECTOR volume level of the master mixer and master volume level of the sub mixer in such a way that the levels of the two models are identical.

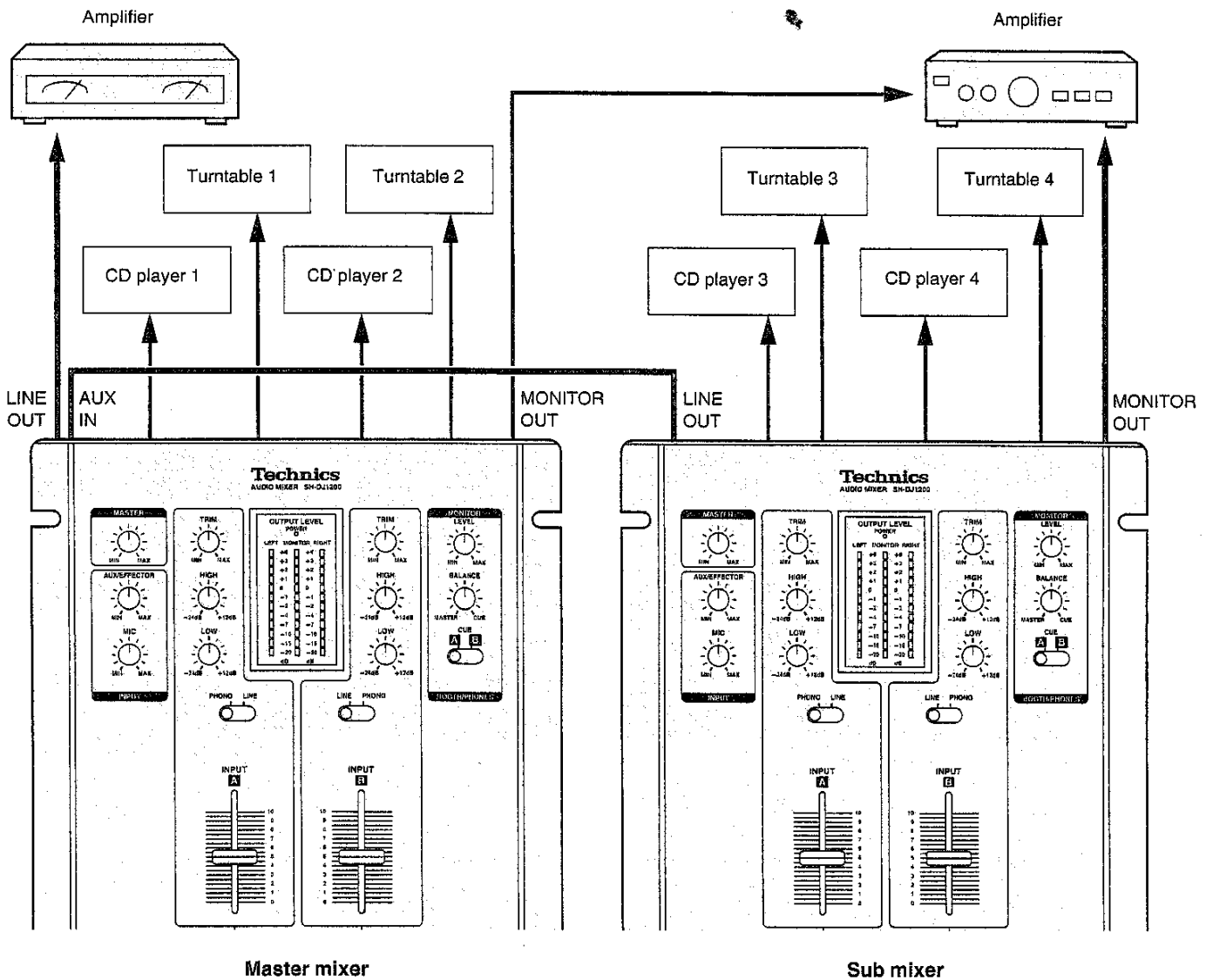

Names of the Parts

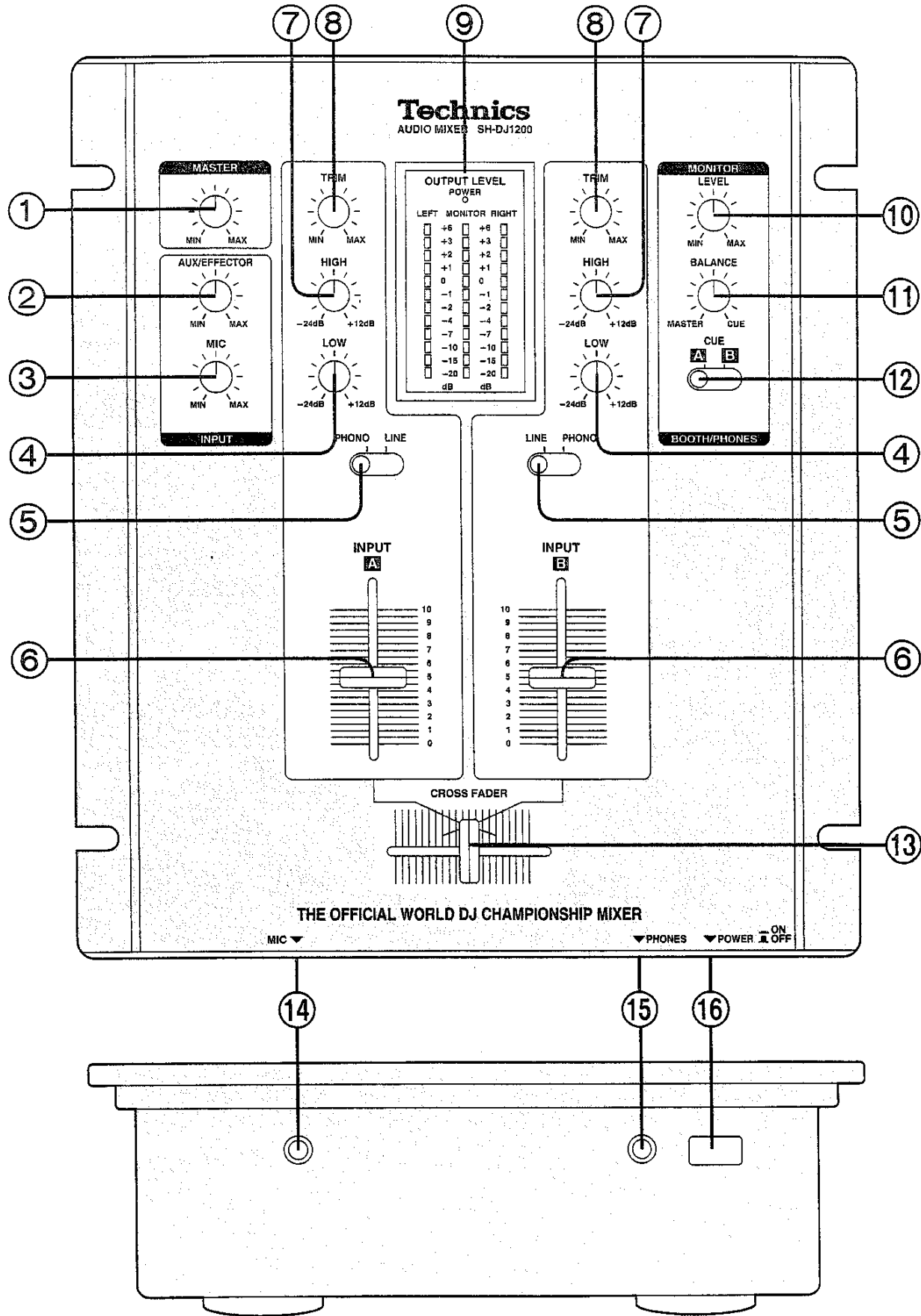

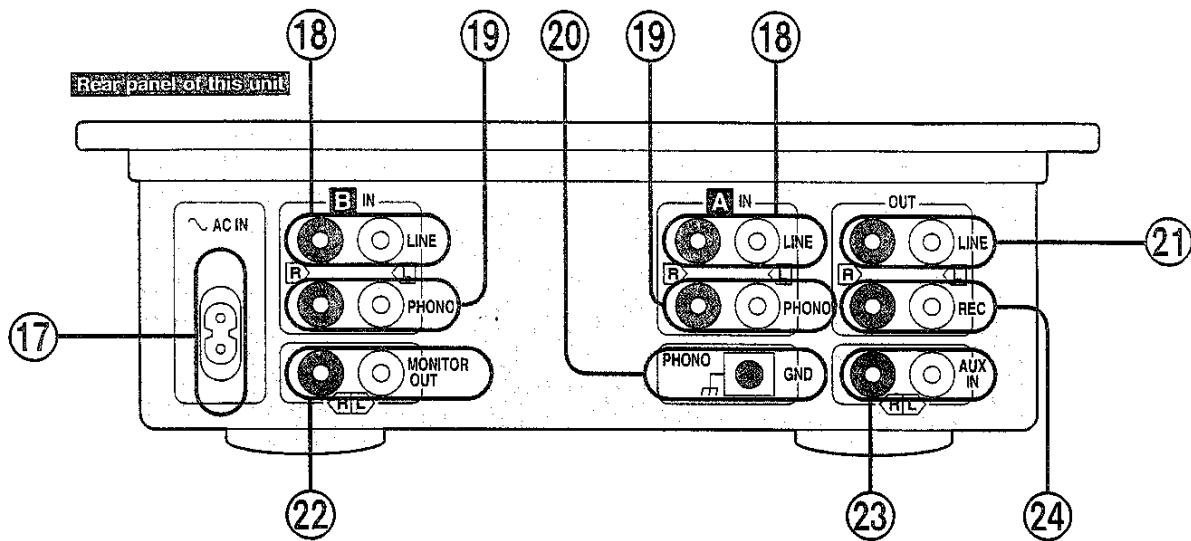

No.	Name
①	Master volume level control (MASTER)
②	AUX/EFFECTOR volume level control (AUX/EFFECTOR)
③	Mic volume level control (MIC)
④	CH A (B) low-range level control (LOW)
⑤	CH A (B) input selector (LINE, PHONO)
⑥	INPUT A (B) control
⑦	CH A (B) high-range level control (HIGH)
⑧	CH A (B) input sensitivity control (TRIM)
⑨	OUTPUT LEVEL meter This indicates the LINE OUT (L and R channels) and MONITOR OUT output levels.
⑩	Monitor volume level control (MONITOR LEVEL)
⑪	Monitor balance control (MONITOR BALANCE) This adjusts the balance between the LINE OUT source and source selected by the CUE switch.
⑫	Headphones monitor selector (CUE) This selects the source to be monitored regardless of the positions of the faders.

No.	Name
⑬	CROSS FADER control This enables the balance between the CH A and CH B input levels to be adjusted.
⑭	Mic input jack (MIC)
⑮	Headphones jack (PHONES)
⑯	Power button (POWER ON/OFF)
⑰	Power input socket (~AC IN)
⑱	CH A (B) LINE IN connector
⑲	CH A (B) PHONO IN connector
⑳	PHONO GND terminal The grounding wire of the turntable must be secured to the ground terminal in order to prevent hum and noise.
㉑	LINE OUT connector
㉒	MONITOR OUT connector
㉓	AUX IN connector
㉔	REC OUT connector

Block Diagram

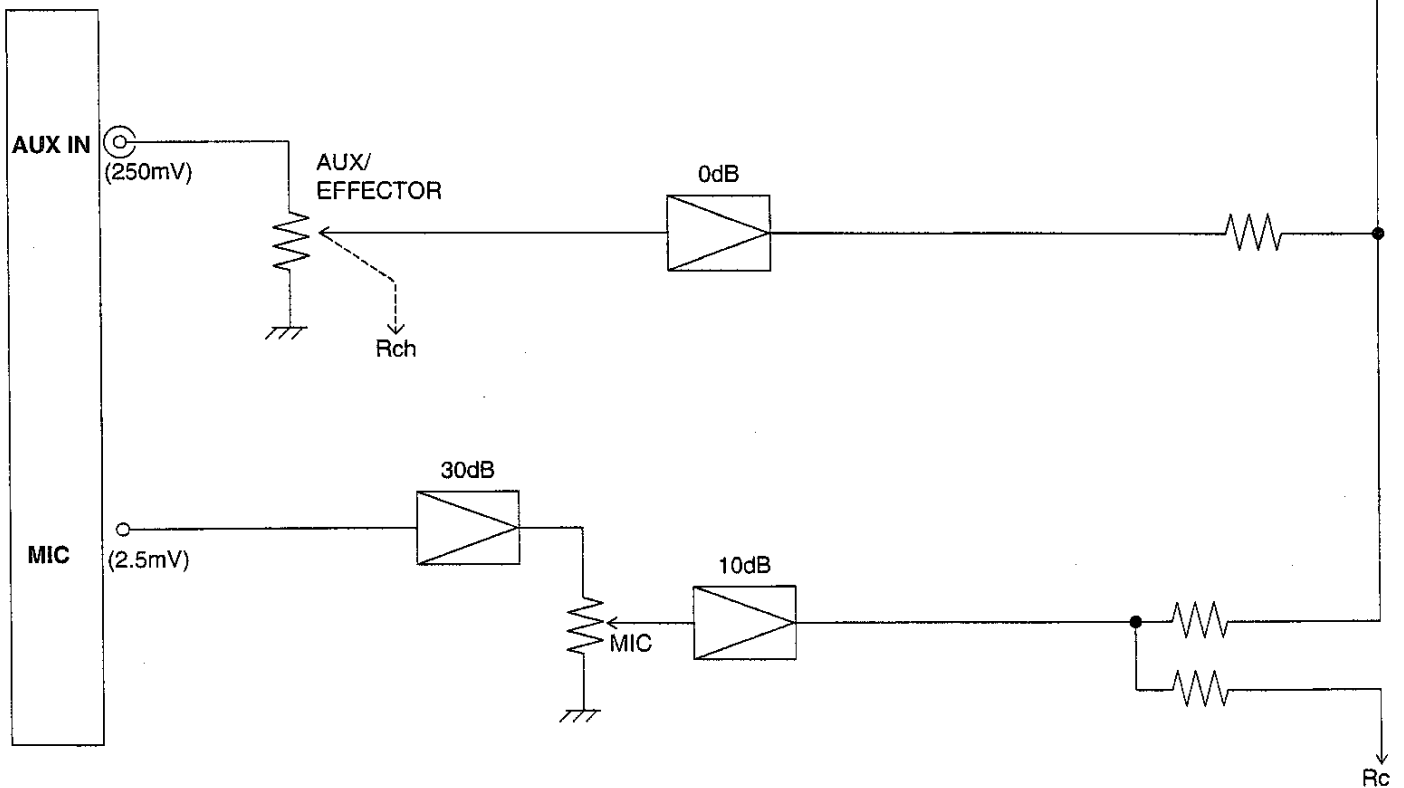
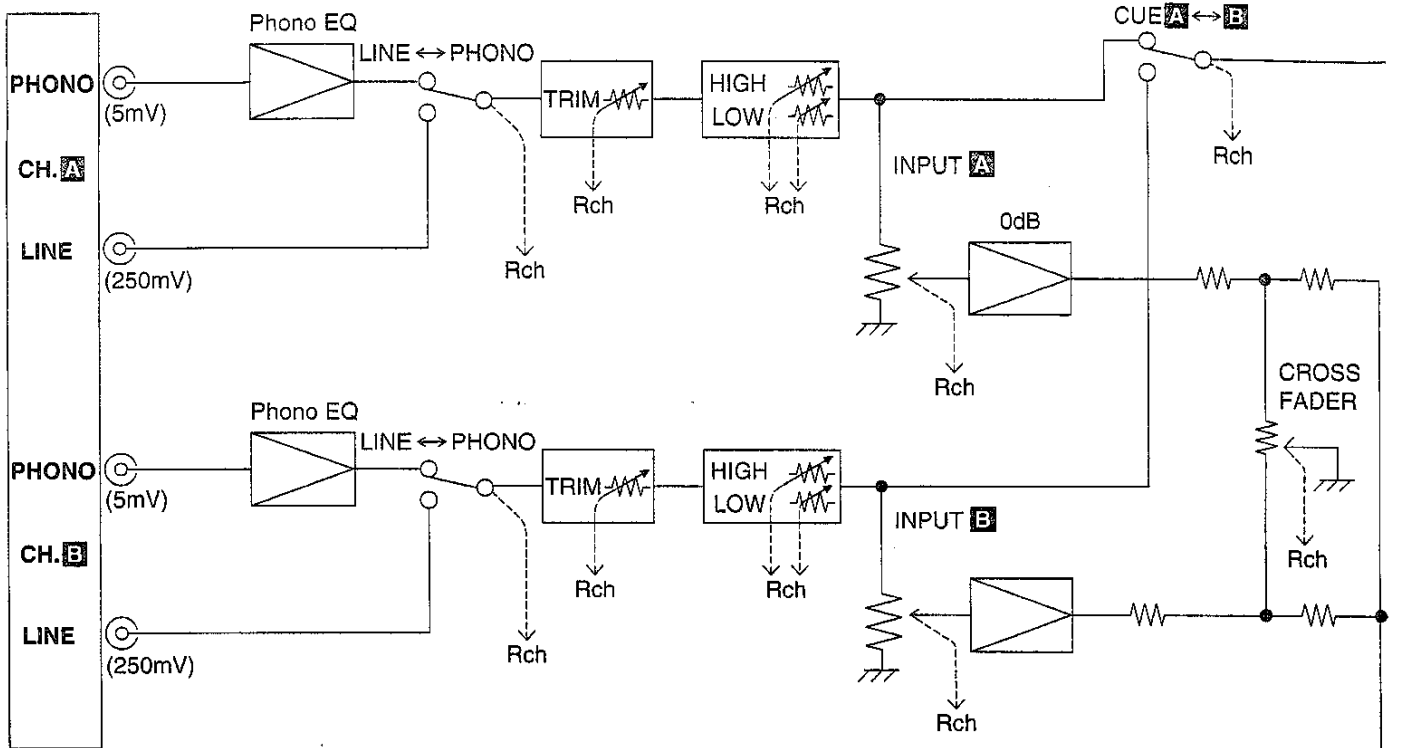

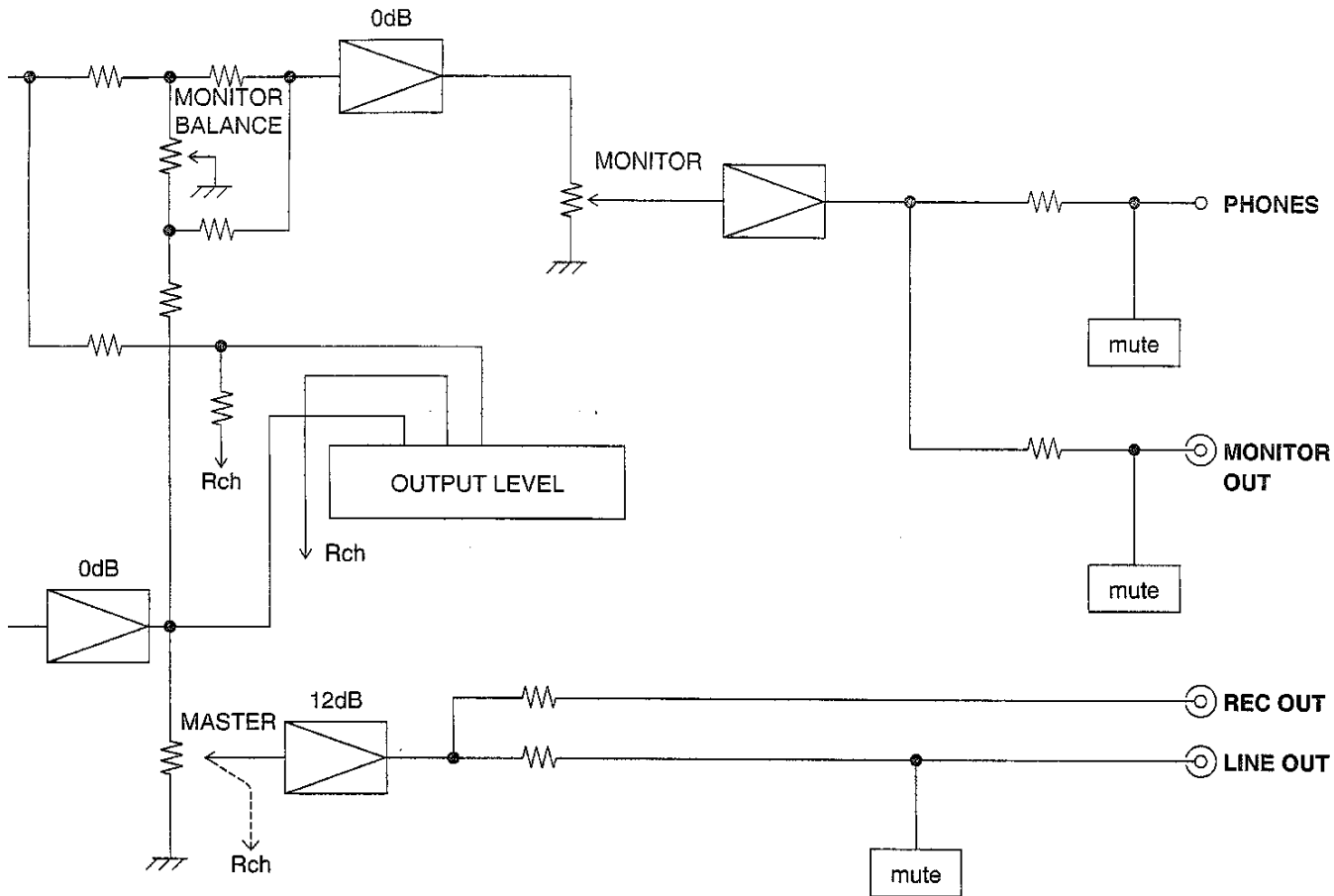

Technical Specifications

■ Input sensitivity/input impedance

PHONO	1.5 to 15 mV/47 kΩ
LINE	100 to 1000 mV/more than 10 kΩ
AUX/EFFECTOR	150 mV/47 kΩ
MIC	0.7 mV/1 kΩ

■ Rated output voltage

LINE	1 V/600Ω
MONITOR	2 V/2.2 kΩ
PHONES	1.5 V/100Ω (100Ω load)
REC	1 V/2.2 kΩ

■ Maximum output voltage (10 kΩ load excluding headphones)

LINE	8 V
MONITOR	8 V (headphones open)
PHONES	1.5 V (100Ω load)
REC	8 V

■ Applicable load impedance

LINE	More than 600Ω
MONITOR	More than 10 kΩ
PHONES	More than 47Ω
REC	More than 10 kΩ

■ Residual hum and noise

Less than 0.2 mV

■ Frequency response

PHONO	30 Hz to 15 kHz (RIAA ±1 dB)
LINE	10 Hz to 70 kHz (-3 dB)
AUX/EFFECTOR	10 Hz to 100 kHz (-3 dB)
MIC	100 Hz to 15 kHz (-3 dB)

■ Tone control characteristics

	12 dB/oct
LOW	+12 dB, -24 dB (63 Hz)
HIGH	+12 dB, -24 dB (10 kHz)

■ General

Power supply	AC 50/60 Hz, 230-240 V
Power consumption	15 W
Dimensions (W×H×D)	260×102×305 mm
Weight	3.4 kg

Note:

Specifications are subject to change without notice.
Weight and dimensions are approximate.

Troubleshooting Guide

Before requesting service for this unit, check the chart below for a possible cause of the problem you are experiencing. Some simple checks or a minor adjustment on your part may eliminate the problem and restore proper operation. If you are in doubt about some of the check points, or if the remedies indicated in the chart do not solve the problem, refer to the directory of Authorized Service Centers (enclosed with this unit) to locate a convenient service center, or consult your dealer for instructions.

Symptom	Checkpoint	Remedial action
No power.	Has the power plug been disconnected?	Connect the power plug securely.
No sound even when power is supplied.	Has the input selector control been set to another source?	Check the source and set the control to the proper position.
	Have any of the units been wrongly connected?	Connect the units properly.
	Is the master level control or another volume level control at the MIN position?	Adjust the volume level controls correctly.
Left and right sound is reversed.	Have any of the units been connected with the left and right channels reversed?	Connect the channels correctly.
Low hum or buzz is heard during play.	Is there a fluorescent light or other electrical appliance or its power cord near any of the connecting cords?	Place the fluorescent light, other appliances or their power cords as far away from the audio mixer as possible.
	Has the turntable's grounding wire been disconnected?	Connect the grounding wire securely.
Fader (slide volume control) fails to move smoothly.	Is one of the faders worn?	Replace with a new fader. (Refer to the Slide Volume Replacement Instructions provided separately.)

Maintenance

Wipe the unit with a soft cloth. To remove stubborn dirt, wipe with cloth moistened with water or soapy water, and then remove the remaining moisture using a dry cloth.

- Do not use alcohol or paint thinners.
- When using a chemically treated cleaning cloth, refer to the instructions accompanying it.

Matsushita Electric Industrial Co., Ltd.
Central P.O. Box 288, Osaka 530-91, Japan

RQT3642-B
F0796R0 (D)